



PULSAR IX Pressure Blast Cabinet



**Clean
Peen
Deburr
Finish**



Model Pulsar IX-P with Power Module

Rear view of Pressure Power Module

Pulsar IX Features:

Safety

- ✓ Worksurface flush with door sill for easier access.
- ✓ Full-length, neoprene-on-fabric gloves resist wear and protect operator.
- ✓ Ceiling-mounted, fluorescent light fixture with abrasive resistant Lexan® cover for extraordinary visibility.
- ✓ Safety interlocks interrupt blasting if either door is opened. (Conforms to US regulations.)
- ✓ Adjustable, heavy-duty chromed latches seal doors tight through years of service.

Productivity

- ✓ High efficiency, 2.0 cu ft. capacity, ASME-coded vessel, fitted with 1" piping, industrial blast hose, couplings, and integrated controls.
- ✓ Unique Air Logic system (pilot actuated) to maximize air flow to the nozzle.
- ✓ Double-wall, sound-insulated doors, with industrial-quality lift-off hinges.
- ✓ 14-gauge steel all-welded construction forms a rigid, long-lasting, cabinet shell.
- ✓ Large window provides 2-1/2 times the viewing area compared to our smaller cabinets.

Convenience

- ✓ Tilt-out window, for tool-free glass changes in minutes.
- ✓ Pressure regulator, gauge, and electric switch mounted within easy reach.
- ✓ Built-in blow-off gun helps keep dust inside the cabinet, not on your floor.

Power Module Features:

- ✓ Handles steel grit (G80 and finer) and steel shot (S-170 and finer)
- ✓ Standard reclaim wear plate.
- ✓ Dual cartridges swing out for replacement.
- ✓ Full access to blast machine for servicing.
- ✓ Adjustable vortex tube.
- ✓ HEPA filter ready.
- ✓ Skid mounted components.

Common Applications

- Remove rust, mill scale, heat scale, and carbon buildup from metals
- Eliminate defects from castings and injection-molded parts
- Beautify metal surfaces
- Etch a variety of materials
- Clean release agents and material buildup from molds
- Extract residual sand from castings

Tungsten Carbide Blast Nozzle

The standard No. 3 tungsten carbide nozzle is perfect for most blasting, while optional boron carbide nozzles stand up to hundreds of hours of blasting with aluminum oxide or other aggressive abrasives. The cabinet's blast and recovery systems can support up to a No. 6 (3/8-inch) nozzle.

S P E C I F I C A T I O N S

PULSAR PRESSURE SYSTEM

Actual space required depends on equipment configurations, options and desired work flow. Allow additional work space for operator and maintenance access.

- A. 57.5" deep (1460mm)
- B. 61" wide (1549mm)
- C. 87" high (2210mm)

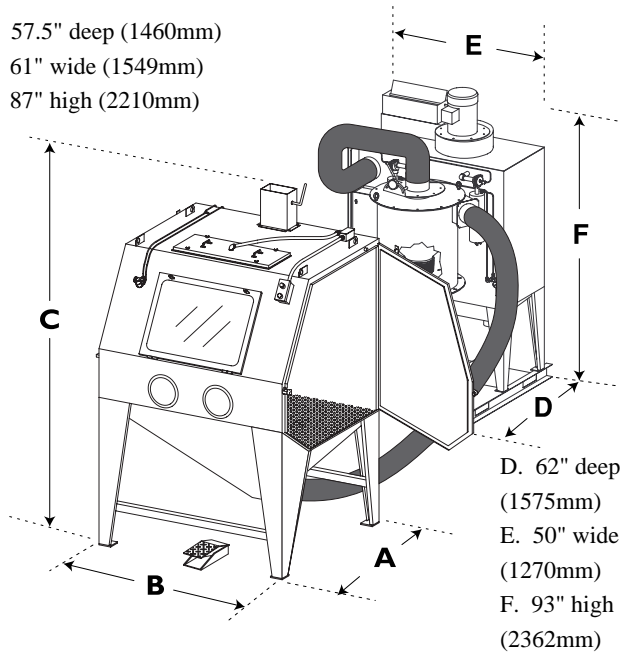

CABINET

Working Chamber Size

Door Opening

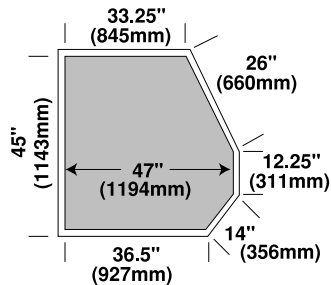
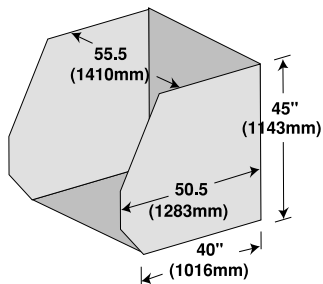

Door interlock system conforms to U.S. government regulations.

Window Size *(safety glass)*

30" wide (762mm) 20" high (508mm)

DUST COLLECTOR

Reverse pulse cartridge dust collectors (which trap 99.7% of dust down to 0.5 micron) allow non-stop, high-production blasting. The polyester-cellulose cartridges are automatically pulse cleaned for maximum filter efficiency. Worn cartridges can be replaced in minutes.

Reverse Pulse Collector Cartridge

208 sq ft filter area per cartridge; RP-2 has two cartridges (416 sq ft)

Clemco is committed to continuous product improvement. Specifications are subject to change without notice.

Clemco Industries is an ISO 9001 certified company.

BLAST/RECLAIM SYSTEM

The Heart of ZERO's Blasting System

Our exclusive media reclaimers continuously extract dust and debris and return properly sized, usable media to the blast system. The standard reclaimer handles most media.

The reclaimer, mounted atop the pressure vessel, automatically refills the blast system with clean, recycled media

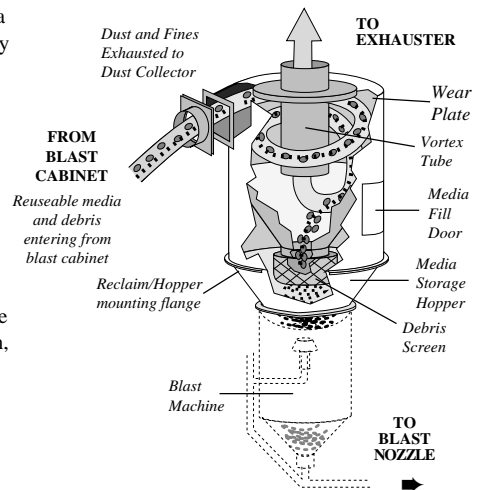

NOZZLES

AIR CONSUMPTION

SIZE	NOZZLE ORIFICE	CFM at 80 PSI	M ³ /Min at 5,5 BAR	CFM at 100 PSI	M ³ /Min at 7 BAR
No. 3	3/16"	38	1,08	45	1,3
No. 4	1/4"	68	1,93	81	2,3
No. 5	5/16"	113	3,20	137	4,0

Cabinets are furnished with a No. 3 tungsten carbide nozzle.

ELECTRICAL

2HP, 220/440V, 3PH, 60HZ, (1.5KW, 220V, 3PH, 50HZ)

ORDERING INFORMATION

Model	Stock No.	Shipping Weight
Pulsar IX-P Pressure blast cabinet with power module	23250	1,735 lb (789 kg)

POPULAR ACCESSORIES

- Adjustable Gun Mount
- Manometer Kit
- Air-powered Vertical Lift Door
- Oscillator Assembly
- Alox Kit
- Timed Door Release
- Curtains (black or white)
- 40-inch Diameter Turntable
- HEPA filter
- Work Car & Track Assembly

Distributed By: