

AEROLYTE[®] Systems

By Clemco Industries Corp.



Bicarbonator Soda Blast Cabinet

**Degrease
Clean
Strip Paint**

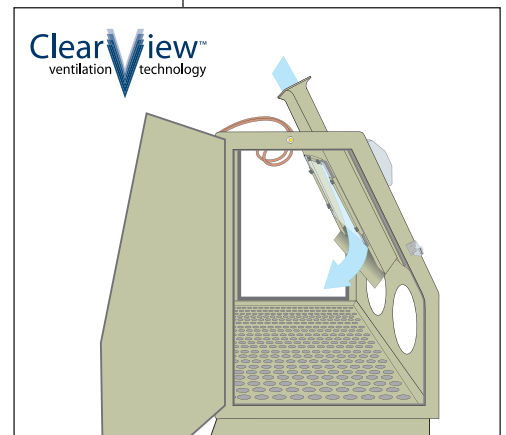

The Aerolyte Bicarbonator Pressure Blast Cabinet is designed specifically for use with sodium bicarbonate media for degreasing, cleaning, and paint stripping without etching the blasted surface. Soda is non-toxic, non-hazardous, and soft, making it ideal for delicate substrates; and it is water-soluble simplifying the process of residual media removal and disposal.

The Aerolyte Bicarbonator Cabinet Features

Safety

- Door interlock system interrupts blasting when either door is opened
- Optional time-delay locking system keeps doors locked for predetermined time
- Double-wall, insulated doors, reduce exterior noise
- Full-opening doors with lift-off hinges maximize work chamber capacity and ease loading large parts
- Full-length, neoprene-on-fabric gloves offer long wear life and operator protection
- Dual 15-watt fluorescent lights illuminate the work chamber and stay cool

Productivity

- Patented ClearView™ targeted high-velocity ventilation technology provides exceptional visibility
- Unique air logic system maximizes air and media flow for blasting
- ASME-code pressure vessel, 0.5 cuft capacity, with 1/2" piping
- Reverse-pulse cartridge dust collector immediately evacuates airborne dust and traps 99.7% of dust down to 0.5 micron
- Robust, adjustable chrome latches seal doors tight through years of service

Convenience

- Tilt-out window allows tool-free glass changes in minutes
- Easy-to-reach pressure regulator, gauge, and electric switch
- Built-in air gun conveniently located inside allows part blow-off inside cabinet

Unique patented ClearView™ ventilation technology provides outstanding visibility during soda blasting, unlike any other cabinet on the market.

Common Applications

- Cylinder heads
- Engine parts
- Transmission valve bodies
- Oil pumps
- Gearbox bodies and parts
- Carburetor bodies and parts
- Fiberglass components
- Automotive body parts
- Aircraft parts
- Delicate substrates

S P E C I F I C A T I O N S

COMPLETE SYSTEM

Actual space required depends on equipment configurations, and desired work flow. Allow additional work space for operator and maintenance access.

Cabinet and Dust Collector
42.5" deep
48" wide
79" high

10" Blast Machine and Hopper
22" wide
42.5" high

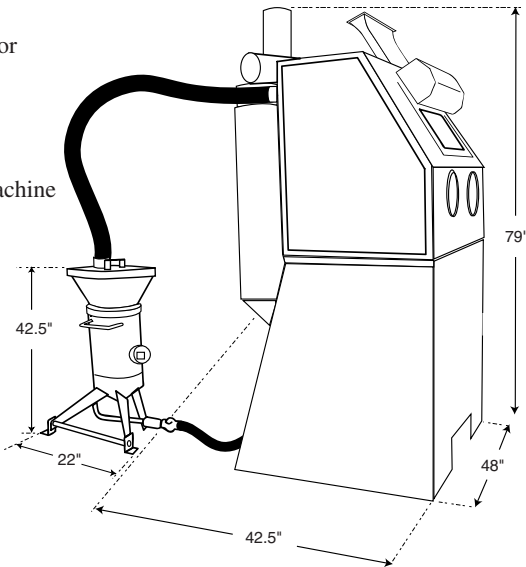

Model Illustrated: 2342B

CABINET

Working Chamber Size

42" wide (1067 mm)
23" deep (584 mm)
30" high (762 mm)

Door Opening

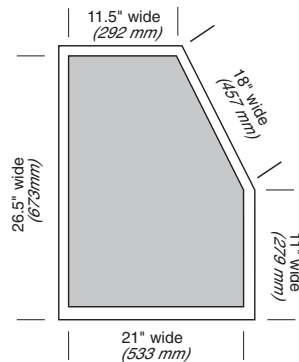

Window Size (safety glass)

19.5" wide (495 mm)
12.5" high (317 mm)

DUST COLLECTOR

The reverse pulse cartridge dust collector traps 99.7% of dust down to 0.5 micron, allowing non-stop, high-production blasting. The polyester-cellulose cartridge is automatically pulse cleaned for maximum filter efficiency. The cartridge can be replaced in minutes.

Filtering Area

195 ft² (18,1m²)

Dust concentration in exhausted air is nominally 5.0 mg/m³.

NOTE: The Bicarbonator Soda Blast Cabinet incorporates technology covered by US Patent No. 5177911.

The Clemco Industries Corp. Quality Management Systems is ISO 9001:2000 certified.

SYSTEM DESCRIPTION

- Model Bicarbonator 2342SB
- Heavy-duty 14-gauge cabinet shell, all-welded construction
- Safety-glass view window, 12" x 19.5"
- Fluorescent lighting with dual 15-watt bulbs
- Heavy-duty industrial-quality adjustable chrome latches
- Unique air-logic system to maximize efficient use of compressed air and provide optimal work chamber visibility
- Cabinet-mounted reverse-pulse dust collector with 1/2 HP motor
- Filter area: 107 square feet
- Dust drum, removable for easy material disposal
- 50 lb capacity (0.5 cu.ft) ASME-code pressure vessel.

POPULAR ACCESSORIES

- Time-delay Door Locks
- Table/work tray w/internal track
- Turntable
- HEPA Filter

NOZZLES

AIR CONSUMPTION

SIZE	NOZZLE ORIFICE	CFM at 80 PSI	M ³ /mn.at 5,5 BAR
No. 2	1/8"	17	0,5
* No. 3	3/16"	38	1,08

*Cabinet is furnished with a No. 3 Tungsten Carbide nozzle.

ELECTRICAL

1/2HP, 115V, 1PH, 60HZ

ORDERING INFORMATION

Model	Reclaim	Dust Collector	Stock No.	Shipping Wt.
Bicarbonator 2342SB	N/A	Reverse Pulse; 195 sq.ft. Filter Area	24748	875 lbs 398 kgs

Distributed By: